

SMT470

High Performance Blue color TOP LED

SMT470 consists of an InGaN LED mounted on the lead frame as TOP LED package and is 200mcd typical of Brightness.

It emits a spectral band of radiation at 470nm.

◆ Specifications

1) Product Name	TOP LED
2) Type No.	SMT470
3) Chip	
(1) Chip Material	InGaN
(2) Peak Wavelength	470nm typ.
4) Package	
(1) Lead Frame Die	Silver Plated
(2) Package Resin	PPA Resin
(3) Lens	Epoxy Resin

◆ Outer dimension (Unit: mm)

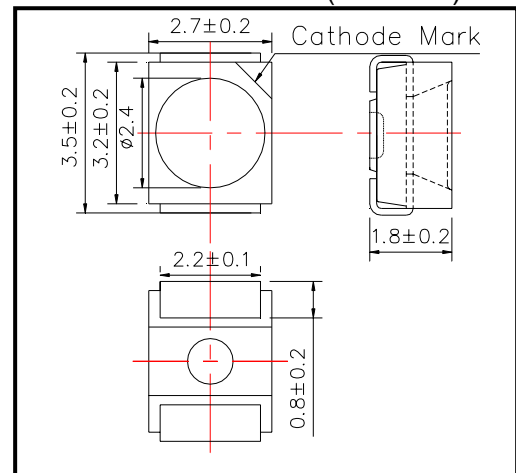

◆ Absolute Maximum Ratings

Item	Symbol	Maximum Rated Value	Unit	Ambient Temperature
Power Dissipation	P_D	120	mW	$T_a=25^\circ\text{C}$
Forward Current	I_F	30	mA	$T_a=25^\circ\text{C}$
Reverse Voltage	V_R	5	V	$T_a=25^\circ\text{C}$
Operating Temperature	T_{OPR}	-20 ~ +80	$^\circ\text{C}$	
Storage Temperature	T_{STG}	-30 ~ +80	$^\circ\text{C}$	
Soldering Temperature	T_{SOL}	240	$^\circ\text{C}$	

‡Soldering condition: Soldering condition must be completed within 3 seconds at 230°C

◆ Electro-Optical Characteristics [$T_a=25^\circ\text{C}$]

Item	Symbol	Condition	Minimum	Typical	Maximum	Unit
Forward Voltage	V_F	$I_F=20\text{mA}$		3.80	4.30	V
Reverse Current	I_R	$V_R=5\text{V}$			10	μA
Total Radiated Power	P_O	$I_F=20\text{mA}$		3.5		mW
Brightness	I_V	$I_F=20\text{mA}$	100	200		mcd
Peak Wavelength	λ_P	$I_F=20\text{mA}$	460	470	480	nm
Half Width	$\Delta\lambda$	$I_F=20\text{mA}$		25		nm
Viewing Half Angle	$\theta_{1/2}$	$I_F=20\text{mA}$		± 55		deg.

‡Total Radiated Power is measured by Photodyne #500

‡Brightness is measured by Tektronix J-16.