

Lead (Pb) Free Product – RoHS Compliant

L635/760-04A Bi-Color LED for medical analysis

Bi-color LED of L635/760-04A consists of DDH structure AlGaAs LEDs mounted on a lead frame with a clear epoxy lens.

On forward bias it emits a band of visible light, which peaks 635nm and 760nm at anode common.

◆ Features

- 1) High Reliability
- 2) High Power
- 3) Anode Common

◆ Specifications

- 1) Product Name Bi-color LED
- 2) Type No. L635/760-04A
- 3) Chip
 - (1) Chip Material AlGaAs (DDH structure)
 - (2) Peak Wavelength 635nm and 760nm typ.
- 4) Package
 - (1) Type Φ 5mm clear molding
 - (2) Resin Material Epoxy Resin
 - (3) Lead Frame Soldered

◆ Outer dimension (Unit: mm)

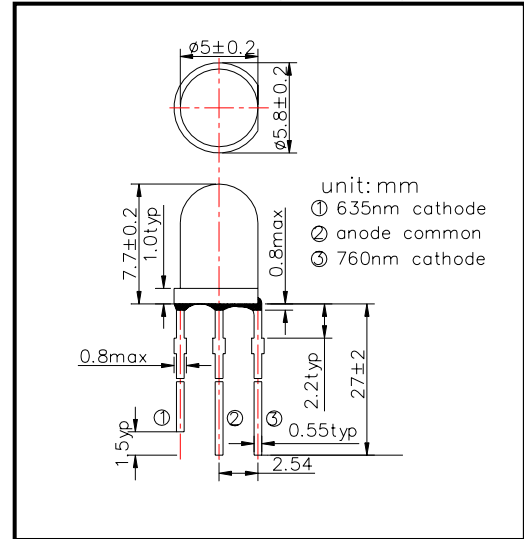

◆ Absolute Maximum Ratings

Item	Symbol	Maximum Rated Value		Unit	Ambient Temperature
		635nm	760nm		
Power Dissipation	PD	100	200	mW	Ta=25°C
Forward Current	IF	50	100	mA	Ta=25°C
Reverse Voltage	IR	5		V	Ta=25°C
Operating Temperature	TOPR	-30 ~ +85		°C	
Storage Temperature	TSTG	-30 ~ +100		°C	
Soldering Temperature	TSOL	260		°C	

‡Soldering condition: Soldering condition must be completed within 3 seconds at 260°C

◆ Electro-Optical Characteristics [Ta=25°C]

Item	Symbol	Condition	Minimum		Typical		Maximum		Unit
			635nm	760nm	635nm	760nm	635nm	760nm	
Forward Voltage	VF	IF=20mA			2.10	1.65	2.30	2.00	V
Reverse Current	IR	VR=5V					10		uA
Total Radiated Power	PO	IF=20mA	0.7	2.0	1.5	4.0	2.5	8.0	mW
Peak Wavelength	λ_P	IF=20mA	630	750	635	760	640	770	nm
Half Width	$\Delta\lambda$	IF=20mA			20	30			nm
Viewing Half Angle	$\theta_{1/2}$	IF=20mA			±20				deg.

‡Total Radiated Power is measured by Photodyne #500

‡Radiant Intensity is measured by Tektronix J-6512