

L850-66-48 epoxy lens type Infrared illuminator

L850-66-48 is a wide viewing and extremely high output power illuminator assembled with a total of 48 high efficiency AlGaAs diode chips, mounted on a metal stem TO-66 with AlN ceramics and covered with double coated clear silicone and epoxy resin.

These devices are designed for high current operation with proper heat sinking to improve thermal conductive efficiency.

◆ Features

- 1) High reliability
- 2) Compact (TO-66) package
- 3) High output power at 850nm

◆ Applications

- 1) For IR search light
- 2) For CCD lighting
- 3) For night vision light source

◆ Specifications

◆ Specifications

- | | |
|---------------------|-------------------------------|
| 1) Product name | IR illuminator |
| 2) Spec. No. | L850-66-48 |
| 3) Chip | |
| (1) Material | AlGaAs |
| (2) Peak wavelength | 850nm |
| 4) Package | |
| (1) Stem | TO-66 stem with AlN |
| (2) Lens | Clear silicone and epoxy lens |

◆ Outer dimension (Unit: mm)

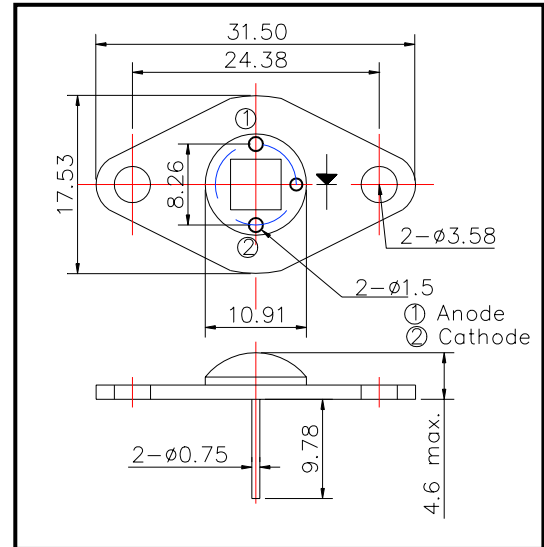

◆ Absolute Maximum Ratings

Item	Symbol	Maximum Rated Value	Unit	Ambient Temp.
Power Dissipation	PD	7.8	W	Ta=25°C
Forward Current	IF	1200	mA	Ta=25°C
Pulse Forward Current	IFP	6	A	Ta=25°C
Reverse Voltage	VR	50	V	Ta=25°C
Operating Temperature	TOPR	-30 ~ +80	°C	
Storage Temperature	TSTG	-30 ~ +110	°C	
Soldering Temperature	TSOL	240	°C	

‡Pulse Forward Current condition: Duty=1% and Pulse Width=1us.

‡Soldering condition: Soldering condition must be completed within 3 seconds at 260°C

◆ Electro-Optical Characteristics

Item	Symbol	Condition	Minimum	Typical	Maximum	Unit
Total Radiated Power	PO	IF=800mA		1200		mW
Total Radiated Power	PO	IF=5A		7000		mW
Radiant Intensity	IE	IF=800mA		300		mW/sr
Forward Voltage	VF	IF=800mA		6.2		V
Reverse Current	VR	IR=10uA	50			V
Peak Wavelength	λP	IF=800mA	840	850	860	nm
Half Width	Δλ	IF=800mA		40		nm
Viewing Half Angle	θ 1/2	IF=800mA		±60		deg.
Rise Time	tr	IF=100mA		30		ns
Fall Time	tf	IF=100mA		20		ns

‡Heat sink is required thermal resistance <8K/W