

SMT750-27

Infrared TOP IR LED with lens

SMT750-27 consists of an AlGaAs LED mounted on the lead frame as TOP LED package with epoxy resin lens and is 15mW/sr typical.

It emits a spectral band of radiation at 750nm.

◆ Outer dimension (Unit:mm)

◆ Specifications

- | | |
|---------------------|----------------------|
| 1) Product Name | TOP IR LED with lens |
| 2) Type No. | SMT750-27 |
| 3) Chip | |
| (1) Chip Material | AlGaAs |
| (2) Peak Wavelength | 750nm typ. |
| 4) Package | |
| (1) Lead Frame Die | Silver Plated |
| (2) Package Resin | PPA Resin |
| (3) Lens | Epoxy Resin |
| (4) Diameter | Φ2.6mm |

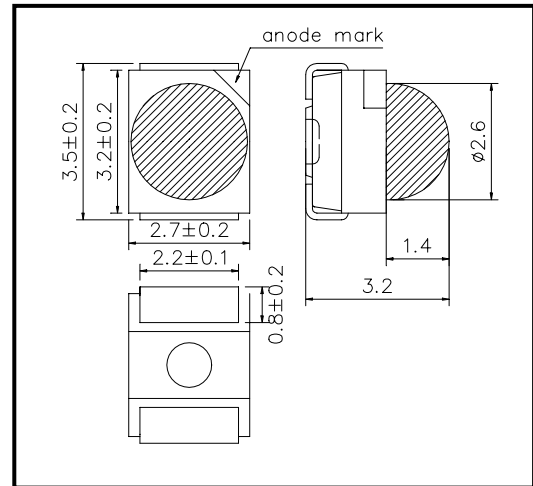

◆ Absolute Maximum Rating

Item	Symbol	Maximum Rated Value	Unit	Ambient Temperature
Power Dissipation	P _D	190	mW	T _a =25°C
Forward Current	I _F	100	mA	T _a =25°C
Pulse Forward Current	I _{FP}	500	mA	T _a =25°C
Reverse Voltage	V _R	5	V	T _a =25°C
Operating Temperature	T _{OPR}	-20 ~ +80	°C	
Storage Temperature	T _{STG}	-30 ~ +80	°C	
Soldering Temperature	T _{SOL}	240	°C	

‡Pulse Forward Current condition: Duty=1% and Pulse Width=10us.

‡Soldering condition: Soldering condition must be completed within 5 seconds at 240°C

◆ Electro-Optical Characteristics [T_a=25°C]

Item	Symbol	Condition	Minimum	Typical	Maximum	Unit
Forward Voltage	V _F	I _F =50mA		1.85	2.00	V
Reverse Current	I _R	V _R =5V			10	uA
Total Radiated Power	P _O	I _F =50mA	12.0	20.0		mW
Radiant Intensity	I _E	I _F =50mA	10.0	15.0		mW/sr
Peak Wavelength	λ _P	I _F =50mA	735	750	765	nm
Half Width	Δλ	I _F =50mA		25		nm
Viewing Half Angle	θ _{1/2}	I _F =50mA		±28		deg.
Rise Time	t _r	I _F =50mA		80		ns
Fall Time	t _f	I _F =50mA		80		ns

‡Total Radiated Power is measured by Photodyne #500

‡Radiant Intensity is measured by Tektronix J-6512.

◆ SMD Application

Recommended reflow soldering profile

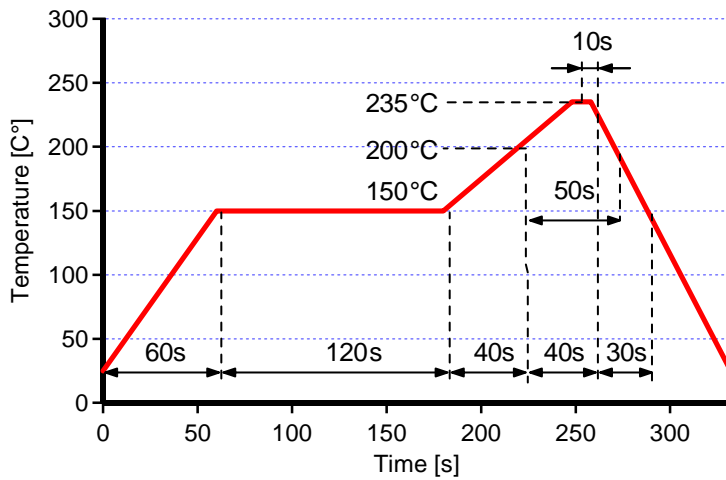

Recommended Land Layout (Unit: mm)

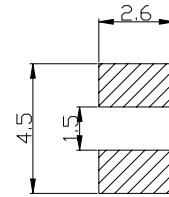

Don't put stress on SMD and a circuit board after soldering.

◆ SMD Packing

Tape and Reel Dimensions (Unit: mm)

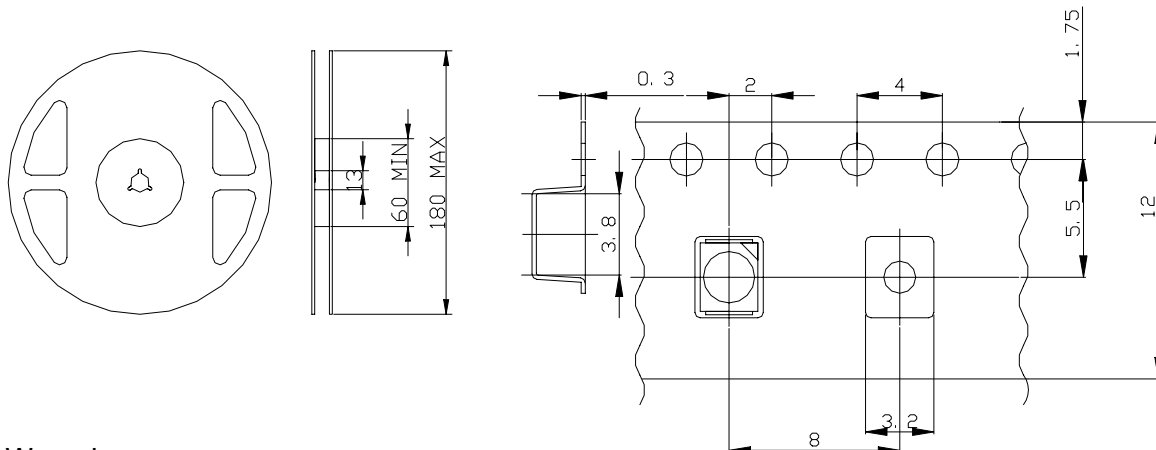

◆ Wrapping

Moisture barrier bag aluminum laminated film with a desiccant to keep out the moisture absorption during the transportation and storage.