

SMT850-23

High Performance Infrared TOP LED with Lens

SMT850-23 consists of an AlGaAs LED mounted on the lead frame as TOP LED package with plastic ball lens and is 22mW typical of output power and 40mW/sr of radiant Intensity. It emits a spectral band of radiation at 850nm.

◆ Specifications

1) Product Name	TOP IR LED
2) Type No.	SMT850-23
3) Chip	
(1) Chip Material	AlGaAs
(2) Chip Dimension	400um*400nm
(3) Peak Wavelength	850nm typ.
4) Package	
(1) Lead Frame Die	Silver Plated
(2) Package Resin	PPA Resin
(3) Lens	Epoxy Resin
(4) Diameter	Φ2.6mm

◆ Outer dimension (Unit:mm)

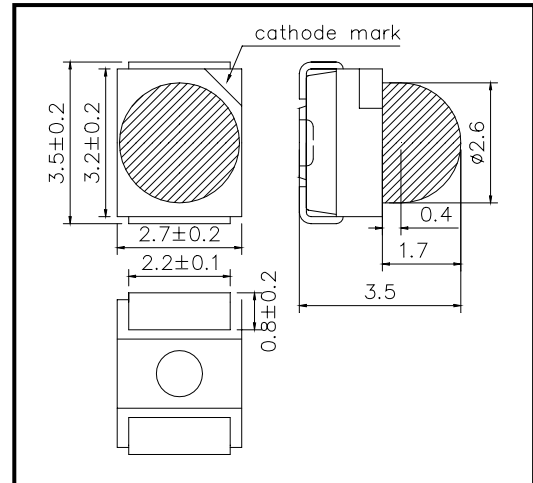

◆ Absolute Maximum Rating

Item	Symbol	Maximum Rated Value	Unit	Ambient Temperature
Power Dissipation	P _D	160	mW	T _a =25°C
Forward Current	I _F	100	mA	T _a =25°C
Pulse Forward Current	I _{FP}	500	mA	T _a =25°C
Reverse Voltage	V _R	5	V	T _a =25°C
Operating Temperature	T _{OPR}	-20 ~ +80	°C	
Storage Temperature	T _{STG}	-30 ~ +80	°C	
Soldering Temperature	T _{SOL}	240	°C	

‡Pulse Forward Current condition: Duty=1% and Pulse Width=10us.

‡Soldering condition: Soldering condition must be completed within 5 seconds at 235°C

◆ Electro-Optical Characteristics [T_a=25°C]

Item	Symbol	Condition	Minimum	Typical	Maximum	Unit
Forward Voltage	V _F	I _F =50mA		1.50	1.70	V
Reverse Current	I _R	V _R =5V			10	uA
Total Radiated Power	P _O	I _F =50mA	16.0	22.0		mW
Radiant Intensity	I _E	I _F =50mA	20	40		mW/sr
Peak Wavelength	λ _P	I _F =50mA	835	850	865	nm
Half Width	Δλ	I _F =50mA		40		nm
Viewing Half Angle	θ _{1/2}	I _F =50mA		±15		deg.
Rise Time	t _r	I _F =50mA		15		ns
Fall Time	t _f	I _F =50mA		10		ns

‡Total Radiated Power is measured by Photodyne #500

‡Radiant Intensity is measured by Tektronix J-6512.

◆ SMD Application

Recommended reflow soldering profile

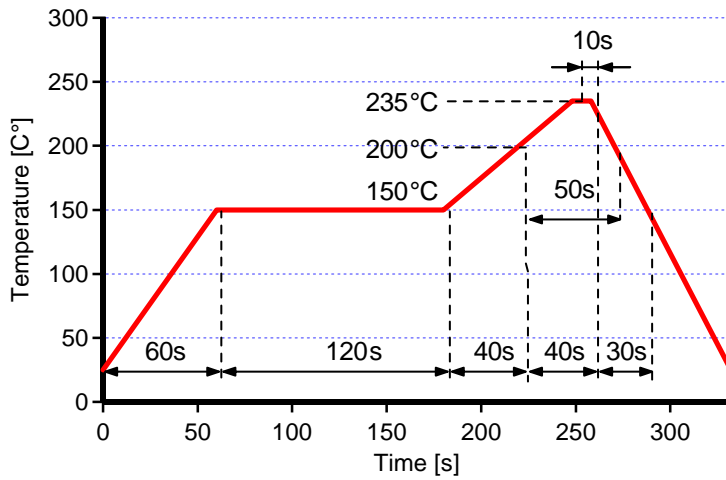

Recommended Land Layout (Unit: mm)

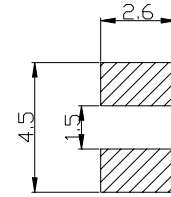

Don't put stress on SMD and a circuit board after soldering.

◆ SMD Packing

Tape and Reel Dimensions (Unit: mm)

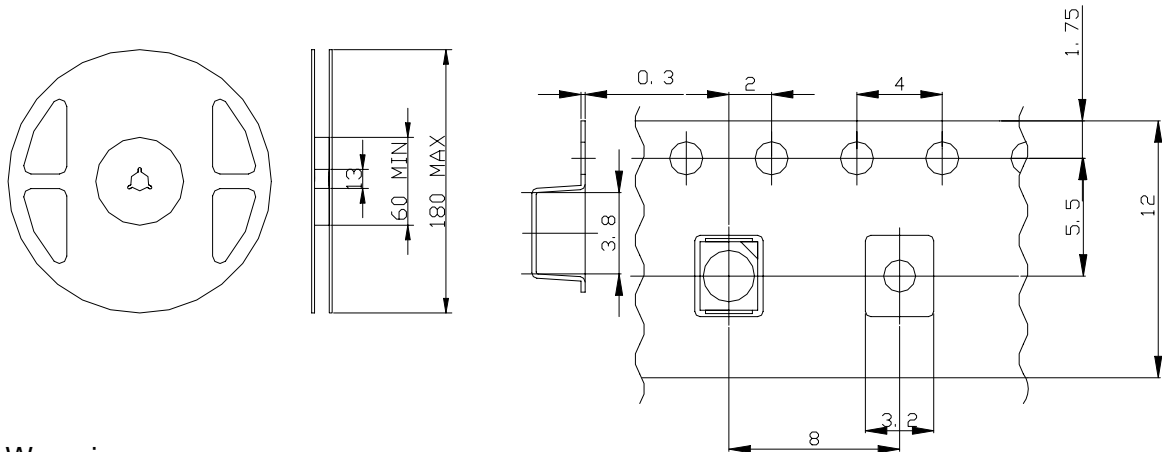

◆ Wrapping

Moisture barrier bag aluminum laminated film with a desiccant to keep out the moisture absorption during the transportation and storage.