

L850-40T52 stem type LED

L850-40T52 is AlGaAs LED mounted on TO-18 stem and hermetically sealed with flat glass can.

On forward bias it emits a spectral band of radiation, which peaks at 850nm.

◆Features

- 1) Wide viewing angle
- 2) High Reliability
- 3) 400micron sq. die

◆Specifications

- | | |
|---------------------|----------------------|
| 1) Product Name | Infrared LED Lamp |
| 2) Type No. | L850-40T52 |
| 3) Chip Spec. | |
| (1) Material | AlGaAs |
| (2) Peak Wavelength | 850nm |
| 4) Package | |
| (1) Type | TO-18 stem |
| (2) Lens | Φ2.4 flat glass lens |
| (3) Cap | Gold plated |

◆Outer dimension (Unit: mm)

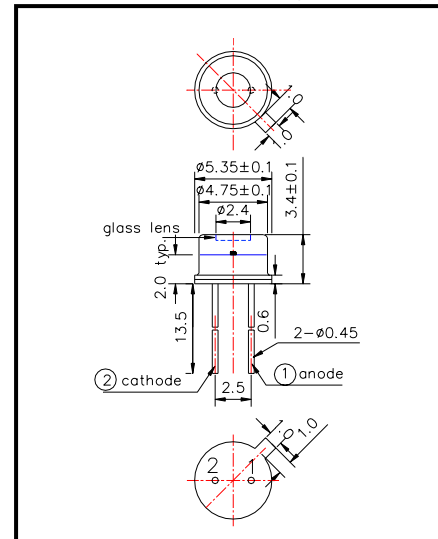

◆Absolute Maximum Ratings

Item	Symbol	Maximum Rated Value	Unit	Ambient Temperature
Power Dissipation	P _D	160	mW	T _a =25°C
Forward Current	I _F	100	mA	T _a =25°C
Pulse Forward Current	I _{FP}	1000	mA	T _a =25°C
Reverse Voltage	V _R	5	V	T _a =25°C
Operating Temperature	T _{OPR}	-30 ~ +80	°C	
Storage Temperature	T _{STG}	-30 ~ +100	°C	
Soldering Temperature	T _{SOL}	260	°C	

‡Pulse Forward Current condition: Duty=1% and Pulse Width=10us.

‡Soldering condition : Soldering condition must be completed within 3 seconds at 260°C

◆Electro-Optical Characteristics

Item	Symbol	Condition	Minimum	Typical	Maximum	Unit
Forward Voltage	V _F	I _F =50mA		1.50	1.70	V
Reverse Current	I _R	V _R =5V			10	uA
Total Radiated Power	P _O	I _F =50mA	5	8		mW
Radiant Intensity	I _E	I _F =50mA		5		mW/sr
Peak Wavelength	λ _P	I _F =50mA	835	850	865	nm
Half Width	Δλ	I _F =50mA		35		nm
Viewing Half Angle	θ _{1/2}	I _F =50mA		±55		deg.
Rise Time	t _r	I _F =50mA		30		ns
Fall Time	t _f	I _F =50mA		25		ns

‡Total Radiated Power is measured by Photodyne #500

‡Radiant Intensity is measured by Tektronix J-6512.