

# L970-40M31 stem type LED

L970-40M31 is GaAs LED mounted on TO-18 stem with ball glass lens, being designed for high beam uses.

On forward bias it emits a spectral band of radiation, which peaks at 970nm.

◆ Outer dimension (Unit:mm)

◆ Features

- 1) High radiated intensity
- 2) High Reliability

◆ Specifications

- |                     |                           |
|---------------------|---------------------------|
| 1) Product Name     | Infrared LED Lamp         |
| 2) Type No.         | L970-40M31                |
| 3) Chip Spec.       |                           |
| (1) Material        | GaAs                      |
| (2) Peak Wavelength | 970nm                     |
| 4) Package          |                           |
| (1) Type            | TO-18 with reflector stem |
| (2) Lens            | Ball glass lens           |
| (3) Cap             | Nickel plated             |

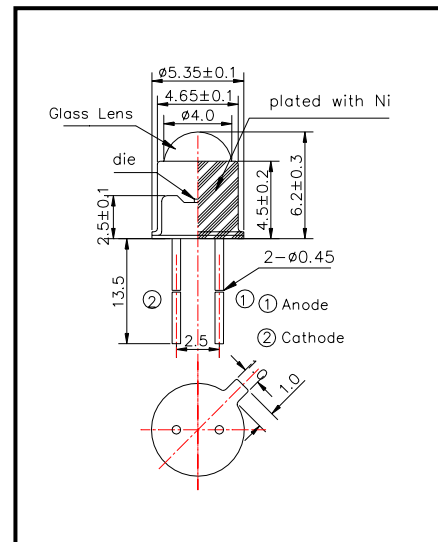

◆ Absolute Maximum Ratings

Item	Symbol	Maximum Rated Value	Unit	Ambient Temperature
Power Dissipation	P <sub>D</sub>	150	mW	T <sub>a</sub> =25°C
Forward Current	I <sub>F</sub>	100	mA	T <sub>a</sub> =25°C
Pulse Forward Current	I <sub>FP</sub>	1000	mA	T <sub>a</sub> =25°C
Reverse Voltage	V <sub>R</sub>	5	V	T <sub>a</sub> =25°C
Operating Temperature	T <sub>OPR</sub>	-30 ~ +80	°C	
Storage Temperature	T <sub>STG</sub>	-30 ~ +100	°C	
Soldering Temperature	T <sub>SOL</sub>	260	°C	

‡Pulse Forward Current condition: Duty=1% and Pulse Width=10us.

‡Soldering condition : Soldering condition must be completed within 3 seconds at 260°C

◆ Electro-Optical Characteristics

Item	Symbol	Condition	Minimum	Typical	Maximum	Unit
Forward Voltage	V <sub>F</sub>	I <sub>F</sub> =50mA		1.30	1.40	V
Reverse Current	I <sub>R</sub>	V <sub>R</sub> =5V			10	uA
Total Radiated Power	P <sub>O</sub>	I <sub>F</sub> =50mA	1.50	2.60		mW
Radiant Intensity	I <sub>E</sub>	I <sub>F</sub> =50mA		10		mW/sr
Peak Wavelength	λ <sub>P</sub>	I <sub>F</sub> =50mA	955	965	975	nm
Half Width	Δλ	I <sub>F</sub> =50mA		50		nm
Viewing Half Angle	θ <sub>1/2</sub>	I <sub>F</sub> =50mA		±15		deg.
Rise Time	t <sub>r</sub>	I <sub>F</sub> =50mA		1000		ns
Fall Time	t <sub>f</sub>	I <sub>F</sub> =50mA		500		ns

‡Total Radiated Power is measured by Photodyne #500

‡Radiant Intensity is measured by Tektronix J-6512.