

SMT850D-21

High Performance Infrared TOP IR LED

SMT850D-21 consists of an AlGaAs LED mounted on the lead frame as TOP LED package and is 24mW typical of output power.

It emits a spectral band of radiation at 850nm.

◆ Specifications

1) Product Name	TOP IR LED
2) Type No.	SMT850D-21
3) Chip	
(1) Chip Material	AlGaAs
(2) Chip Dimension	0.35mm*0.35mm
(3) Peak Wavelength	850nm typ.
4) Package	
(1) Lead Frame Die	Silver Plated
(2) Package Resin	PPA Resin
(3) Lens	Epoxy Resin
(4) Diameter	Φ3.1mm

◆ Outer dimension (Unit: mm)

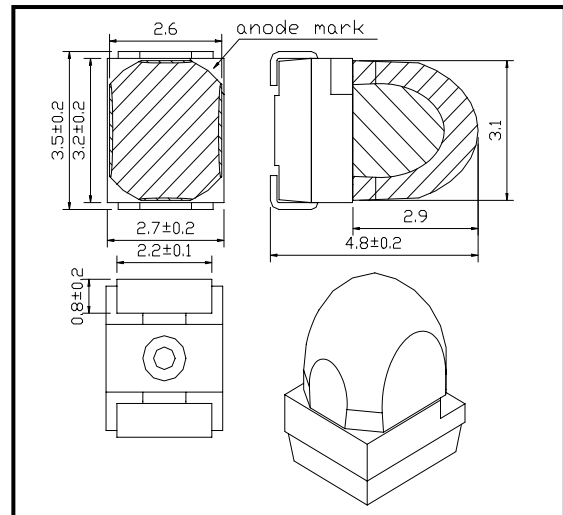

◆ Electro-Optical Characteristics [Ta=25°C]

Item	Symbol	Maximum Rated Value	Unit	Ambient Temperature
Power Dissipation	P _D	175	mW	Ta=25°C
Forward Current	I _F	100	mA	Ta=25°C
Pulse Forward Current	I _{FP}	1,000	mA	Ta=25°C
Reverse Voltage	V _R	5	V	Ta=25°C
Junction Temperature	T _J	100	°C	
Thermal Resistance	R _{thja}	185	K/W	
Operating Temperature	T _{OPR}	-30 ~ +80	°C	
Storage Temperature	T _{STG}	-30 ~ +80	°C	
Soldering Temperature	T _{SOL}	255	°C	

‡Pulse Forward Current condition: Duty=1% and Pulse Width=10us.

‡Soldering condition: Soldering condition must be completed within 10 seconds at 255°C

◆ Electro-Optical Characteristics [Ta=25°C]

Item	Symbol	Condition	Minimum	Typical	Maximum	Unit
Forward Voltage	V _F	I _F =50mA DC		1.55	1.70	V
		I _F =100mA, tp=20ms		1.60	1.80	
Reverse Current	I _R	V _R =5V			10	uA
Total Radiated Power	P _O	I _F =50mA DC	17.0	24.0		mW
		I _F =100mA, tp=20ms		48.0		
Radiant Intensity	I _E	I _F =50mA DC		130		mW/sr
		I _F =100mA, tp=20ms		250		
Peak Wavelength	λ _P	I _F =50mA DC	840	855	870	nm
Half Width	Δλ	I _F =50mA DC		28		nm
Viewing Half Angle	θ _{1/2}	I _F =50mA DC		±5		deg.
Rise Time	t _r	I _F =50mA DC		15		ns
Fall Time	t _f	I _F =50mA DC		10		ns

‡Total Radiated Power is measured by Photodyne #500

‡Radiant Intensity is measured by Tektronix J-6512.